

***CM INDUSTRIES***  
**INC.**

# TWC 400 & 500AUTO

Automatic, Air-Cooled, MIG Welding Gun



## PARTS LIST

MADE IN USA

CM Industries, Inc.  
505 Oakwood Rd. Lake Zurich, IL 60047  
ph: 847-550-0033 fx: 847-550-0444  
email: [sales@cmindustries.com](mailto:sales@cmindustries.com)  
[www.cmindustries.com](http://www.cmindustries.com)

April 2020 v1

# PARTS LIST - Replacement Parts for TWC 400 & 500 AUTO

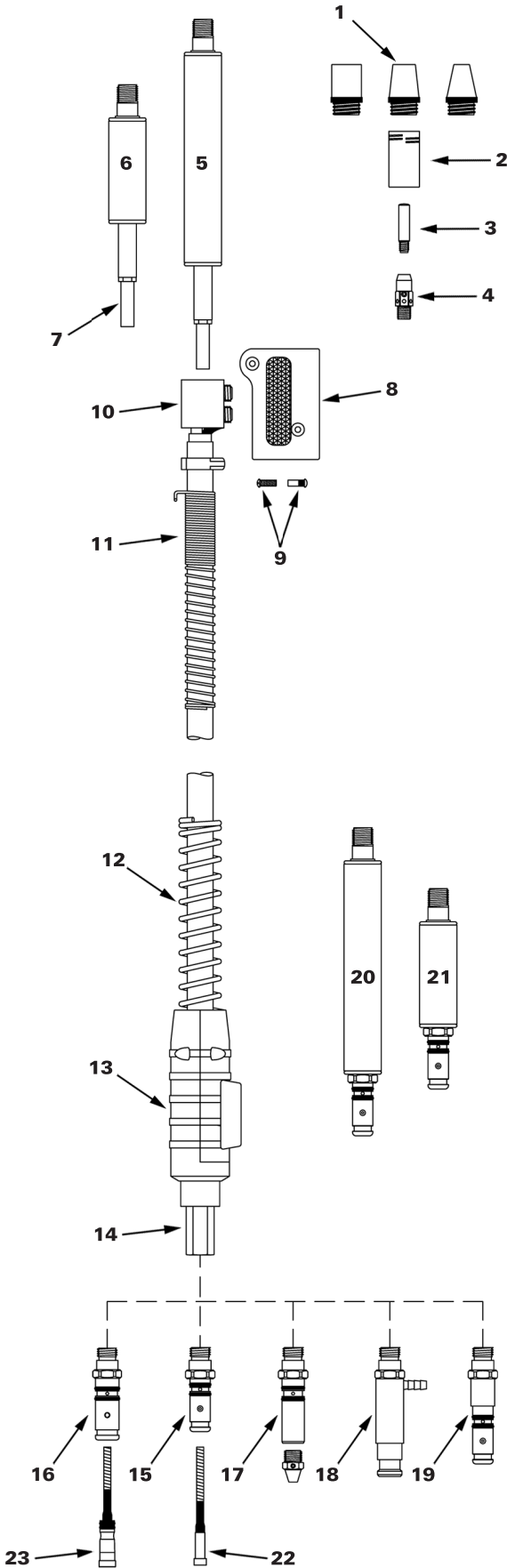

ITEM #	PART #		DESCRIPTION
	400AUTO	500AUTO	
1	C24CT-62-S	C25CT-62	Nozzle
	See <i>Nozzle Selection</i>		Nozzles, Optional Available
2	See <i>Contact Tip Selection</i>		Contact Tip
3	C34CT	C35CT	Insulator
4	C54A	N/A	Diffuser
	N/A	C55SW	Diffuser, for .035" - 1/16"
	N/A	C55	Diffuser, for 5/64"
	N/A	C55H	Diffuser, for 3/32" - 7/64"
5	C64TAM-N	C65TAM-N	AUTO Body w/ Nipple
6	C64STAM-N	C65STAM-N	AUTO Body w/ Nipple - Short
7	C64N	C65N	Gas Hose Nipple
8	C185		Connector Case w/ Screws
9	C125FM		Binder Post & Screw
10	C104		Cable Connector Block Assembly
11	C234-12S	C145-6S	Front Cable Support Spring
12	C350R-230-10S		Rear Cable Support Spring
13	CM6RC		Connector Case
14	CM170-4H	CM170-5H	Power Pin Adaptor
15	C350-174H	N/A	Power Pin, Tweco® #4
16	N/A	C176S-H	Power Pin, Tweco® #5
17	C350-174MH C175M-N	CEL176-MH C175M-N	Power Pin, Miller® Power Pin Cap
18	C350-174LH	CEL176-LH	Power Pin, Lincoln® LN
19	C350-174LPMH	N/A	Power Pin, Lincoln® PM & LF
20	C64TAM-174		AUTO Body - Direct Mount
21	C64STAM-174		AUTO Short Body - Direct Mount
22	See <i>Liner Selection</i>		Liner for 400AUTO
23	See <i>Liner Selection</i>		Liner for 500AUTO



Scan this QR Code to take you directly to the Technical Info page of [cmindustries.com](http://cmindustries.com)

# Consumable Selection

## Nozzles (Optional Available)

### Heavy Duty - 2 Piece 400 Amp



C24CT-37-S 3/8" I.D.  
 C24CT-50-S 1/2" I.D.  
 C24CT-62-S 5/8" I.D.  
 C24CT-75-S 3/4" I.D.

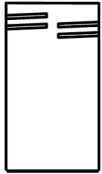

C34CT Insulator

### Heavy Duty - 2 Piece 500 Amp



C25CT-50 1/2" I.D.  
 C25CT-62 5/8" I.D.  
 C25CT-75 3/4" I.D.



C35CT Insulator

## Contact Tips



### 14H Series

C14H-35 H.D., .035" 0.9mm  
 C14H-40 H.D., .040" 1.0mm  
 C14H-45 H.D., .045" 1.2mm  
 C14H-52 H.D., .052" 1.4mm  
 C14H-116 H.D., 1/16" 1.6mm  
 C14AH-364 H.D., Aluminum, 3/64"  
 C14AH-116 H.D., Aluminum, 1/16"



### 15H Series

C15H-35 H.D., .035" 0.9mm  
 C15H-40 H.D., .040" 1.0mm  
 C15H-45 H.D., .045" 1.2mm  
 C15H-52 H.D., .052" 1.4mm  
 C15H-116 H.D., 1/16" 1.6mm  
 C15H-564 H.D., 5/64" 2.0mm  
 C15H-332 H.D., 3/32" 2.4mm  
 C15H-764 H.D., 7/64" 2.8mm  
 C15AH-364 H.D., Aluminum, 3/64"  
 C15AH-116 H.D., Aluminum, 1/16"



### 15HFC Series

C15HFC-35 H.D., .035" 0.9mm  
 C15HFC-40 H.D., .040" 1.0mm  
 C15HFC-45 H.D., .045" 1.2mm  
 C15HFC-52 H.D., .052" 1.4mm  
 C15HFC-116 H.D., 1/16" 1.6mm  
 C15HFC-564 H.D., 5/64" 2.0mm  
 C15HFC-332 H.D., 3/32" 2.4mm  
 C15HFC-764 H.D., 7/64" 2.8mm

## Liners

### 400 Amp

C44-3545-15 15', .035"-.045"  
 C44-3545-25 25', .035"-.045"  
 C44-116-15 15', .062"  
 C44-116-25 25', .062"  
 C44-564-15 15', 5/64"  
 C44-564-25 25', 5/64"

### 400 Amp - Aluminum

C44N-3545-15 Nylon 15', .035"-.045"  
 C44N-116-15 Nylon 15', .062"

\* Euro Connectors only accept  
 44 Series Liners

### 400 Amp - Direct Mount

C44-3545-1 1', .035"-.045"  
 C44-116-1 1', .062"  
 C44-564-1 1', 5/64"

### 400 Amp - Aluminum

C44N-3545-1 Nylon 1', .035"-.045"  
 C44N-116-1 Nylon 1', .062"

### 500 Amp - Direct Mount

C45-3545-1 1', .035"-.045"  
 C45-116-1 1', .062"  
 C45-564-1 1' 5/64"  
 C45H-332-1 1' 3/32"  
 C45H-764-1 1' 7/64"

### 500 Amp - Aluminum

C45N-3545-1 Nylon 1' .035"-.045"  
 C45N-116-1 Nylon 1' 3/64"-.062"  
 C45SN-116-1 Steel/Nylon 1' .062"  
 C45TF-116-1 Teflon 1' 3/64"-.062"

### 500 Amp

C45-3545-15 15' .035"-.045"  
 C45-3545-25 25' .035"-.045"  
 C45-116-15 15' .062"  
 C45-116-25 25' .062"  
 C45-564-15 15' 5/64"  
 C45-564-25 25' 5/64"  
 C45H-332-15 15' 3/32"  
 C45H-332-25 25' 3/32"  
 C45H-764-15 15' 7/64"  
 C45H-764-25 25' 7/64"  
 C45N-3545-15 15' .035"-.045"  
 C45N-116-15 15' 3/64"-.062"

### 500 Amp - Aluminum

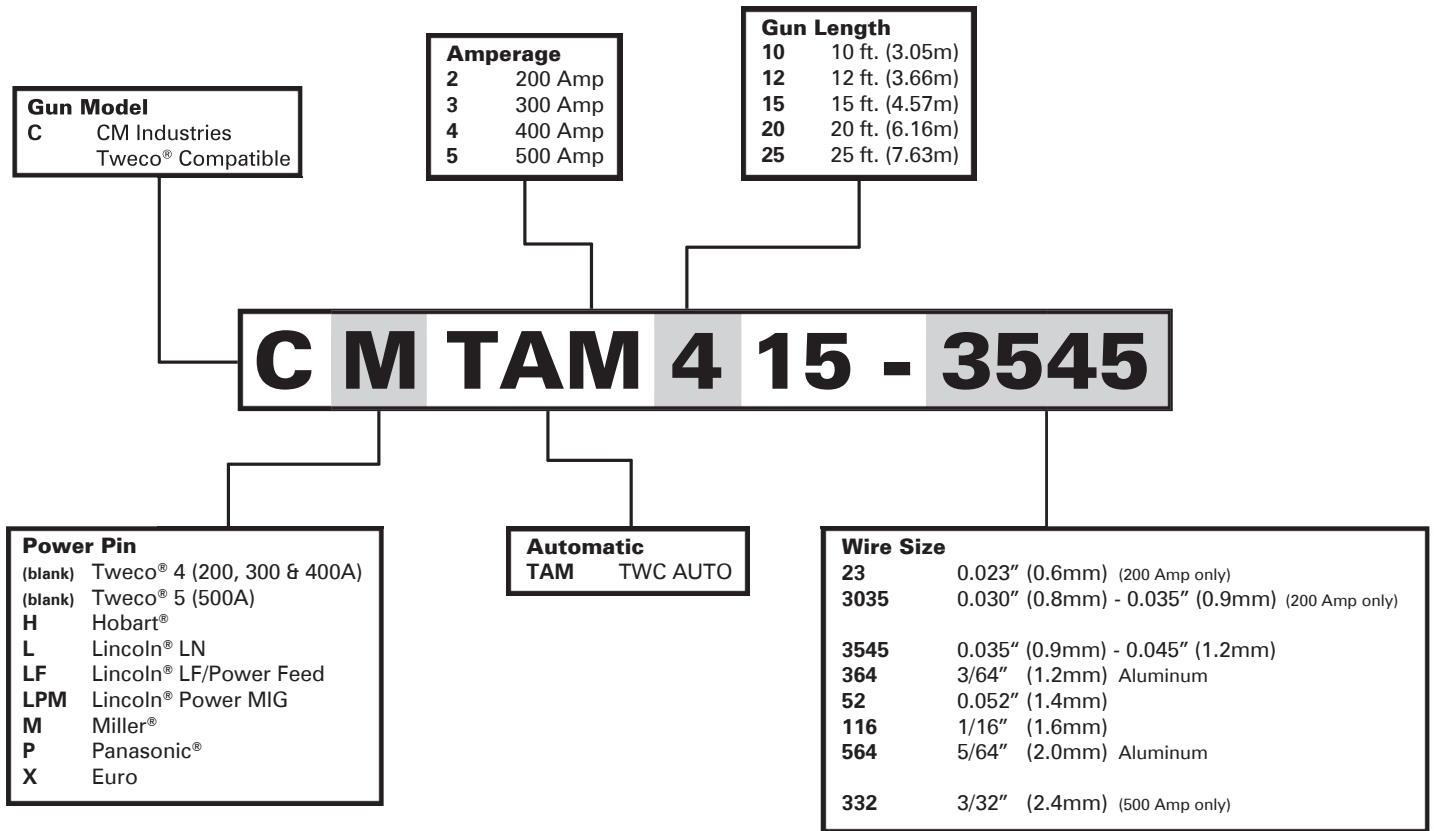

C45SN-116-15 Steel/Nylon 15' .062"  
 C45TF-116-15 Teflon 15' 3/64"-.062"

# Ordering Information



## SAFETY WARNINGS! READ BEFORE USE

 The symbols shown below are used throughout this manual to call attention to and identify possible hazards. When you see the symbol, watch out, and follow the related instructions to avoid the hazard. The safety information given below is only a summary of the more complete safety information found in the welding power source Owner's Manual.

 Read and follow all Safety Standards.  
 Only qualified persons should install, operate, maintain, and repair this equipment. A qualified person is defined as one who, by possession of a recognized degree, certificate, or professional standing, or who by extensive knowledge, training and experience, has successfully demonstrated ability to solve or resolve problems relating to the subject matter, the work, or the project and has received safety training to recognize and avoid the hazards involved.

 During operation, keep everybody, especially children, away.

### **ELECTRIC SHOCK can kill.**

- Always wear dry insulating gloves.
- Insulate yourself from work and ground.
- Do not touch live electrode or electrical parts.
- Replace worn, damaged, or cracked guns or cables.
- Turn off welding power source before changing contact tip or gun parts.
- Keep all covers and handle securely in place.

### **FUMES AND GASES can be hazardous.**

- Keep your head out of the fumes.
- Ventilate area, or use breathing device. The recommended way to determine adequate ventilation is to sample for the composition and quantity of fumes and gases to which personnel are exposed.
- Read and understand the Safety Data Sheets (SDSs) and the manufacturer's instructions for adhesives, coatings, cleaners, consumables, coolants, degreasers, fluxes, and metals.

### **WELDING can cause fire or explosion.**

- Do not weld near flammable material.
- Do not weld on containers that have held combustibles, or on closed containers such as tanks, drums, or pipes unless they are properly prepared according to AWS F4.1 and AWS A6.0 (see Safety Standards).
- Watch for fire; keep extinguisher nearby.
- Read and understand the Safety Data Sheets (SDSs) and the manufacturer's instructions for adhesives, coatings, cleaners, consumables, coolants, degreasers, fluxes, and metals.

### **HOT PARTS can burn.**

- Allow gun to cool before touching.
- Do not touch hot metal.
- Protect hot metal from contact by others.



### **MOVING PARTS can injure.**

- Keep away from moving parts.
- Keep away from pinch points such as drive rolls.



### **ARC RAYS can burn eyes and skin.**

- Arc rays from the welding process produce intense visible and invisible (ultraviolet and infrared) rays that can burn eyes and skin. Sparks fly off from the weld.
- Wear an approved welding helmet fitted with a proper shade of filter lenses to protect your face and eyes from arc rays and sparks when welding or watching (see ANSI Z49.1 and Z87.1 listed in Safety Standards).
  - Wear approved safety glasses with side shields under your helmet.
  - Use protective screens or barriers to protect others from flash, glare and sparks; warn others not to watch the arc.
  - Wear body protection made from durable, flame-resistant material (leather, heavy cotton, wool). Body protection includes oil-free clothing such as leather gloves, heavy shirt, cuffless trousers, high shoes, and a cap.



### **BUILDUP OF GAS can injure or kill.**

- Shut off compressed gas supply when not in use.
- Always ventilate confined spaces or use approved air-supplied respirator.



### **NOISE can damage hearing.**

- Noise from some processes or equipment can damage hearing.
- Check for noise level limits exceeding those specified by OSHA.
  - Use approved ear plugs or ear muffs if noise level is high.
  - Warn others nearby about noise hazard.



### **WELDING WIRE can injure.**

- Keep hands and body away from gun tip when trigger is pressed.

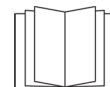

### **READ INSTRUCTIONS.**

- Read and follow all labels and the Owner's Manual carefully before installing, operating, or servicing unit.
- Read the safety information at the beginning of the manual and in each section.
- Use only genuine replacement parts from the manufacturer.
- Perform installation, maintenance, and service according to the Owner's Manuals, industry standards, and national, state, and local codes.

### **CALIFORNIA PROPOSITION 65 WARNING**

This product contains chemicals, including lead, known to the State of California to cause cancer, birth defects, or other reproductive harm. Wash hands after use. (California Health & Safety Code Section 25249.5)