

CM INDUSTRIES **INC.**

Water Coolers **WC2500 & WC3500**



Operating Manual and Parts List

MODEL	PART#	BTU/HOURS	GALLONS	LITER	VOLTS	AMPS	HZ
WC2500	680-25-100	12,000	2.5	9.4	115	5.0	50/60
WC2500	680-25-102	12,000	2.5	9.4	230	2.5	50/60
WC3500	690-25-100	15,000	3	11.4	115	5.0	50/60
WC3500	690-25-102	15,000	3	11.4	230	2.5	50/60

**DO NOT INSTALL, OPERATE, OR REPAIR THIS EQUIPMENT
WITHOUT READING THIS OPERATING MANUAL**

MADE IN USA

CM INDUSTRIES
INC.

July 2017

505 Oakwood Rd. Lake Zurich, IL 60047
ph: 847-550-0033 fx: 847-550-0444
email: sales@cmindustries.com
www.cmindustries.com

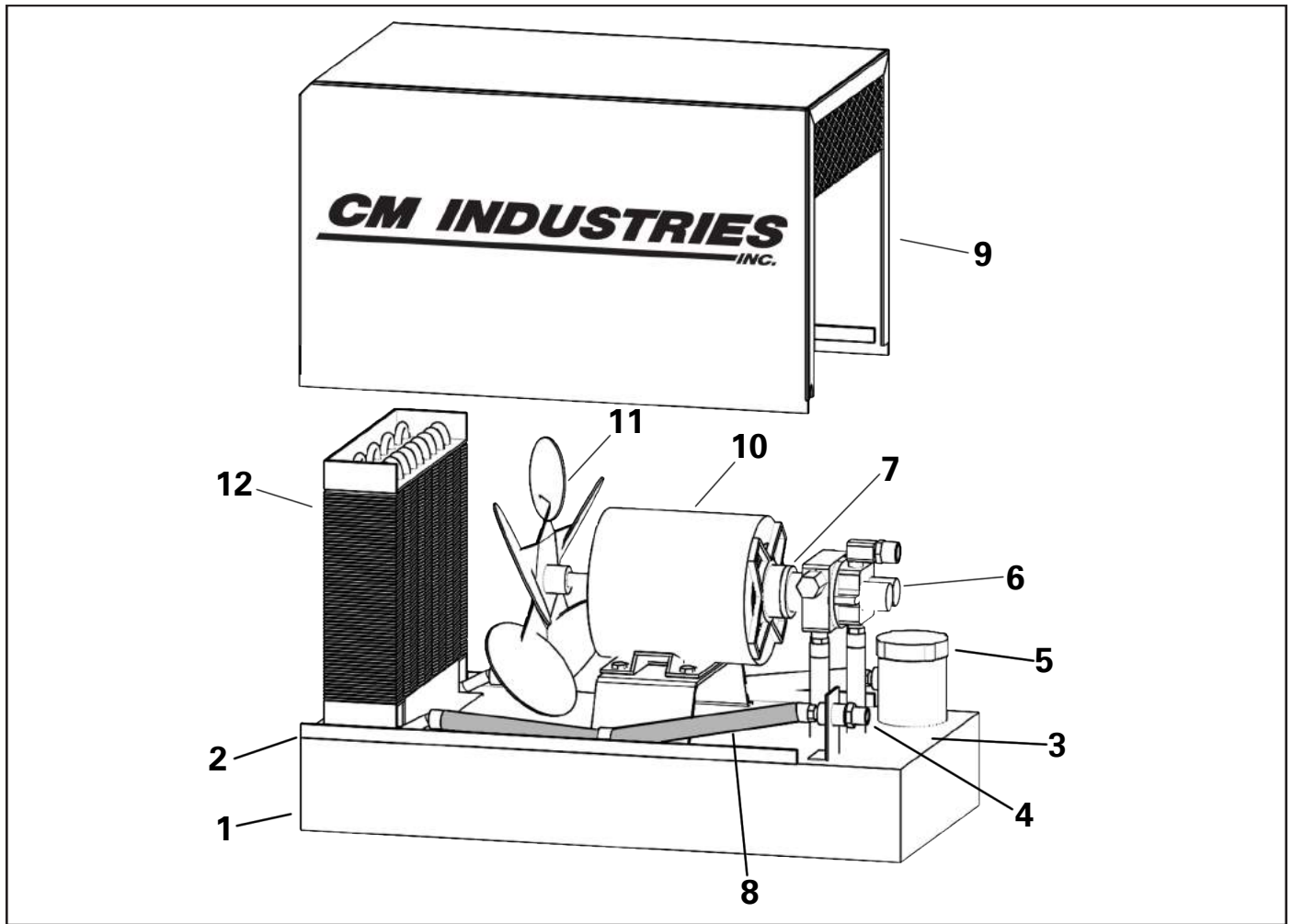

WC2500 - 2.5 GL STAINLESS STEEL WATER COOLER

Specifications:

Dimensions:

18" Long x 9 1/4" Wide x 12 3/8" High
(45.8 cm x 23.5 cm x 31.4 cm)

Reservoir:

2.5 Gallon Capacity

Pump Capacity:

100 psi max. 1.5 gpm (5.68 lpm) @ 50 psi.
1.8 gpm (6.81 lpm) @ 60 psi.

Motor Voltage:

115V or 230VAC, Single Phase, 50/60 Hz

Amperage:

5.0/6.8, 2.5/3.4

Heat Exchanger:

High Efficiency, Copper Core, Rustproof, 12,000 BTU

#	PART #	DESCRIPTION
1	680-30-020	Tank
2	680-30-021	Tank Gasket
3	680-30-022	Tank Cover Plate
4	680-30-023	Inert Gas Adapter
5	680-30-024	Sight Glass Assembly
6	680-30-067	Pump, Rotary Vane
6a	680-30-069	Pump Screen
7	680-30-068	Clamp, Pump to Motor
8	680-30-025	Rubber Hose
9	680-35-026	Hood
10	680-30-061	Motor 115/230V 50/60Hz
11	680-30-027	Fan, 8"
12	680-30-028	Radiator

Water Connections:

5/8"-18 UNC Left-Handed Inert Gas Fittings

Net Weight:

40 lbs. (18.2 kg)

Approximate Shipping Weight:

42 lbs. (19.1 kg)

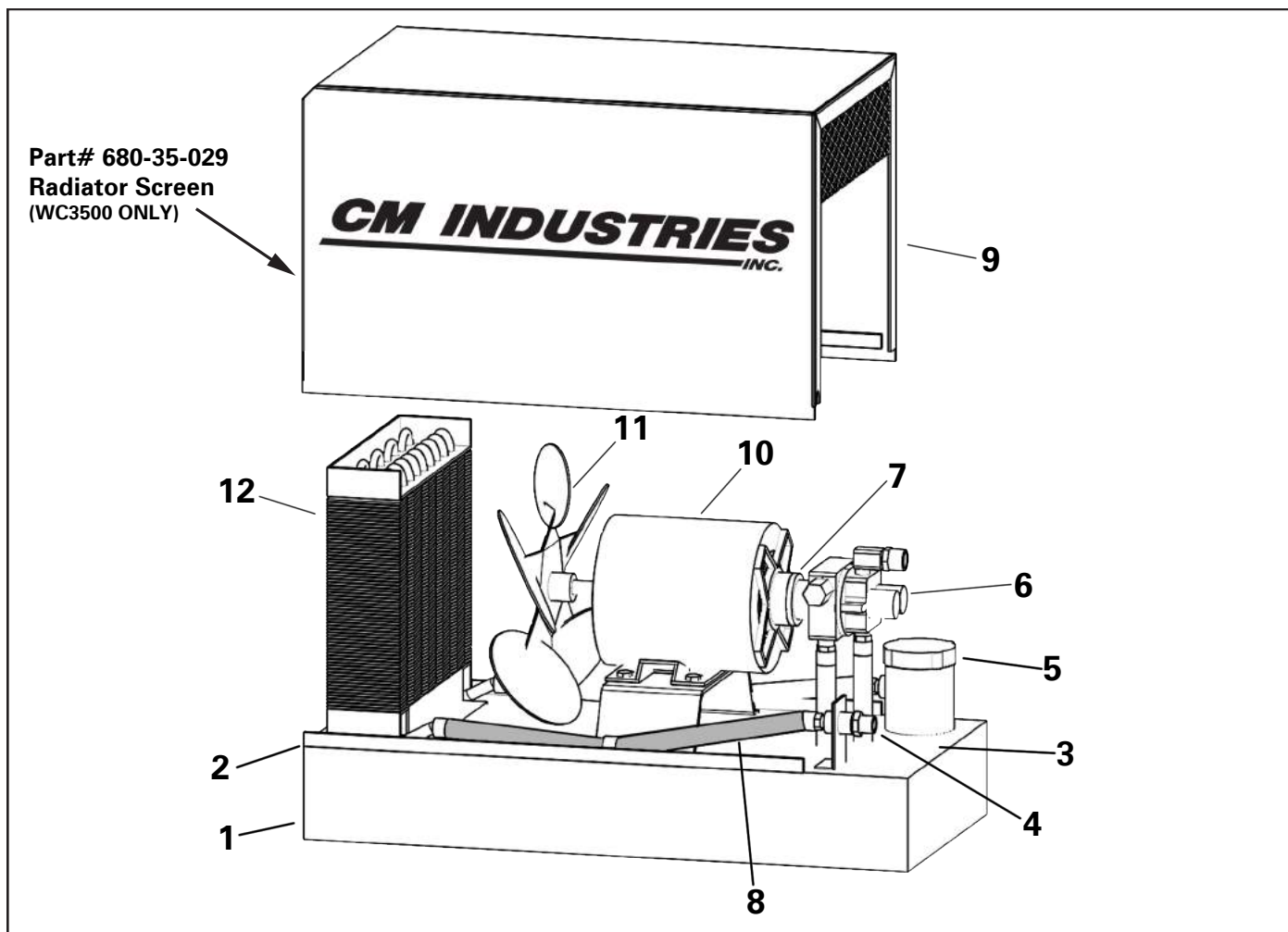

WC3500 - 3 GL STAINLESS STEEL WATER COOLER

Specifications:

Dimensions:

23" Long x 11" Wide x 14 3/4" High
(58.4 cm x 27.9 cm x 37.5 cm)

Reservoir:

3 Gallon Capacity

Pump Capacity:

100 psi max. 1.5 gpm (5.68 lpm) @ 50 psi.
1.8 gpm (6.81 lpm) @ 60 psi.

Motor Voltage:

115V or 230VAC, Single Phase, 50/60 Hz

Amperage:

5.0/6.8, 2.5/3.4

Heat Exchanger:

High Efficiency, Copper Core, Rustproof, 15,000 BTU

#	PART #	DESCRIPTION
1	680-35-020	Tank
2	680-35-021	Tank Gasket
3	680-35-022	Tank Cover Plate
4	680-30-023	Inert Gas Adapter
5	680-30-024	Sight Glass Assembly
6	680-30-067	Pump, Rotary Vane
6a	680-30-069	Pump Screen
7	680-30-068	Clamp, Pump to Motor
8	680-35-025	Rubber Hose
9	680-35-026	Hood
10	680-30-061	Motor 115/230V 50/60Hz
11	680-35-027	Fan, 10"
12	680-35-028	Radiator

Water Connections:

5/8"-18 UNC Left-Handed Inert Gas Fittings

Net Weight:

43 lbs. (19.5 kg)

Approximate Shipping Weight:

45 lbs. (20.5 kg)