

# BNZ 14A & 15A AIR-COOLED MIG GUN

Replacement Suitable for Binzel®

RATING	GUN ORDERING PART NUMBER		POWER PIN Direct Connect
<b>160-180 Amp CO2 @ 60% Duty Cycle</b>  <b>140-150 Amp Mixed Gas @ 60% Duty Cycle</b>  <b>Wire Capacity: 0.023" (0.6mm) - 0.045" (1.2mm)</b>	<b>14A</b>	<b>15A</b>	Euro Century® Lincoln® "LN" Lincoln® Power MIG™ Miller® Tweco® #4
	700-14-010 700-14-C10 700-14-L10 700-14-R10 700-14-M10 700-14-T10	700-15-010 700-15-C10 700-15-L10 700-15-R10 700-15-M10 700-15-T10	
xx = Standard lengths of 10, 12, 15, 20, and 25 ft. Custom lengths also available.			

#	Part Number	Description
1.	165-15-001	Nozzle, Conical, 1/2" I.D., Std.
2.	165-15-002	Nozzle, Cylindrical, 5/8" I.D.
3.	165-15-011	Nozzle, Conical Small, 3/8" I.D.
4.	165-15-003	Nozzle, Spot, 5/8" I.D.
5.	150-06-102	Contact Tip, M6, .024" 0.6mm
	150-08-102	Contact Tip, M6, .030" 0.8mm, Std.
	150-09-102	Contact Tip, M6, .035" 0.9mm
	150-10-102	Contact Tip, M6, .040" 1.0mm
	150-12-102	Contact Tip, M6, .045" 1.2mm
6.	035-14-006	Nozzle Holder, Gas Diffuser, Left Handed
6a.	035-15-001	Nozzle Spring
7.	051-13-445	Swan Neck Assembly, 45° Left Handed (14A)
	051-15-445	Swan Neck Assembly, 45° Left Handed (15A)
	051-15-445	Swan Neck Assembly, 45° Left Handed (15A)
	051-15-001	Swan Neck Assembly, Flexible (15A) (Includes items 6-10)
8.	046-15-010	Head Insulator
9.	290-01-010	Lock Nut, M10 x 1
10.	047-15-002	Replacement Boot
11.	290-01-014	Hex Coupler (14A)
	290-01-015	Hex Coupler (15A)
12.	047-00-100	Body Insulator (15A)
13.	170-14-001	Handle Assembly w/out Switch (14A)
13a.	170-14-100	Trigger Switch (14A)
14.	170-66-005	Handle Screw (15A)
15.	170-66-009	Handle Post (15A)
16.	170-66-002	Handle Assembly Complete w/ Screws (15A)
16a.	170-66-000	Trigger Only (15A)
17.	185-26-001	Cable Support Spring (15A)
18.	300-05-003	Trigger Wire Connector (14A)
	300-05-004	Trigger Wire Connector (15A)

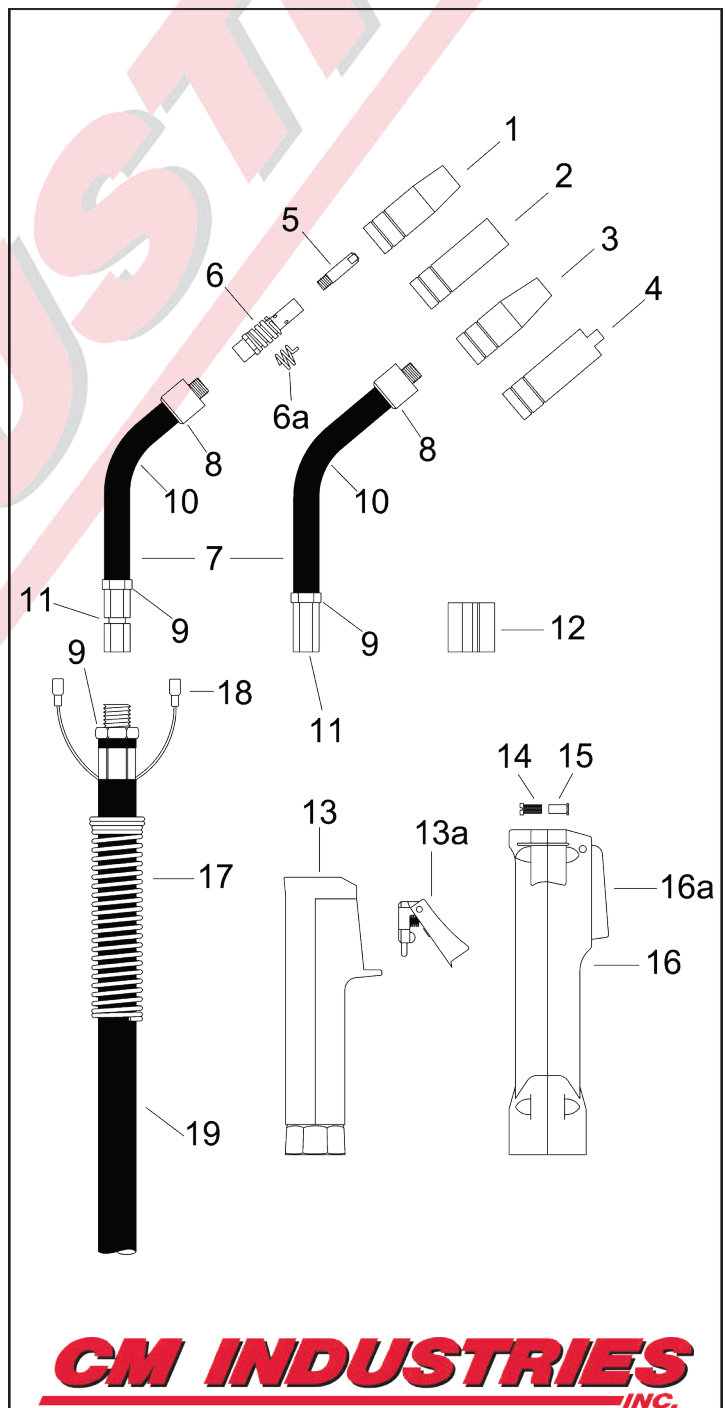

**CM INDUSTRIES**  
INC.

#	Part Number	Description
19.	210-15-010	Power Cable, 10'
	210-15-012	Power Cable, 12'
	210-15-015	Power Cable, 15'
20.	260-25-002	Adaptor Support
21.	285-01-001	Adaptor Support Screw
22.	300-05-010	Male Electrical Connector
23.	401-00-001	Adaptor Nut
24.	300-05-009	Female Electrical Connector
25.	401-02-014	Connector Block, Complete
26.	285-03-002	Male Pin w/ Lead
27.	285-00-002	O-Ring, Connector Block
28.	401-01-001	Liner Retaining Nut
29.	401-02-012	Connector Plug Block
30.	401-02-016	Connector Plug, Hobart/Tweco/Lincoln P.M.
31.	C224	O-Ring
32.	401-01-004	Liner Retaining Plug
33.	401-02-017	Connector Plug, Miller
34.	M079-974	O-Ring, Miller
35.	401-01-002	Liner Nut, Miller
36.	401-02-015	Connector Plug, Lincoln
37.	300-05-001	Electrical Plug, Miller
38.	300-05-002	Electrical Plug, Lincoln
39.	241-26-016	Liner #26, 15', .023"-.035"
	241-22-016	Liner #22, 15', .035"-.045"
40.	255-18-010	Teflon Liner #18, 10', .023"-.035"
	255-18-010	Teflon Liner #18, 10', .023"-.035"
	255-18-010	Teflon Liner #18, 10', .023"-.035"
	255-10-010	Teflon Liner #10, 10', .035"-.045"
	255-10-012	Teflon Liner #10, 12', .035"-.045"
	255-10-015	Teflon Liner #10, 15', .035"-.045"
41.	259-10-001	Repl. Collet, Teflon Liner #10 & #18

