

BND 500TL

AIR-COOLED MIG GUN w/ CMI "Taper-LOCK" Consumables

Replacement Suitable for Bernard®

RATING	GUN ORDERING PART NUMBER w/ CMI "Taper-LOCK" Consumables	POWER PIN Direct Connect
500 Amp CO2 @ 100% Duty Cycle 375 Amp Mixed Gas @ 100% Duty Cycle Wire Capacity: 0.035" (0.9mm) - 7/64" (2.8mm)	BQ50xxAE4EBC BQ50xxAE4EEC BQ50xxAE4EHC BQ50xxAE4ELC BQ50xxAE4ESC BQ50xxAE4EUC BQ50xxAE4EMC BQ50xxAE4ETC	Bernard® Euro Hobart® Lincoln® "LN" Lincoln® "LF" Lincoln® Power MIG™ Miller® Tweco® #4
xx = Standard lengths of 10, 12, 15, 20, and 25 ft. Custom lengths also available.		

#	Part Number	Description
1.	152-30-50C 152-30-62C 152-30-75C	Nozzle H.D., Copper 1/2", 1/8" Tip Recess Nozzle H.D., Copper 5/8", 1/8" Tip Recess Nozzle H.D., Copper 3/4", 1/8" Tip Recess
CMI "Taper-LOCK" Contact Tips		
2.	155-1-035 155-1-040 155-1-045 155-1-364 155-1-052 155-1-062 155-1-564 155-1-332 155-1-764	H.D. Contact Tip, .035" (0.9mm) H.D. Contact Tip, .040" (1.0mm) H.D. Contact Tip, .045" (1.2mm) H.D. Contact Tip, 3/64" (1.2mm) H.D. Contact Tip, .052" (1.4mm) H.D. Contact Tip, .062" (1.6mm) H.D. Contact Tip, 5/64" (2.0mm) H.D. Contact Tip, 3/32" (2.4mm) H.D. Contact Tip, 7/64" (2.8mm)
3.	154-R505	Diffuser H.D., for Taper-LOCK™ Tip
5.	154-1	Replacement Retaining Ring
6.	154-2	Replacement O-Ring
6.	KR50-2	Neck Insulator
7.	BQT3-30 BQT3-45 BQT3-60 BQT5-30 BQT5-45 BQT5-60 BQT5-80	Body Tube, Medium 30° Body Tube, Medium 45° Body Tube, Medium 60° Body Tube, Long 30° Body Tube, Long 45° Body Tube, Long 60° Body Tube, Long 80°
8.	B4780	Insulator Hex Nut
8a.	B1840057	Plastic Lock Nut
8b.	B1840031	Silicone Rubber Seal
9.	B4438	Hang Up Hook
10.	B4407	Post Fastener
11.	B4409 B4426	Handle Screw Screw/Post Kit
12.	B4408	Handle Kit w/ Screws
12a.	185-40-001	Handle Spring
13.	B4422	Trigger Assembly
14.	B4513B	End Fitting
15.	B4416	Cone Nut

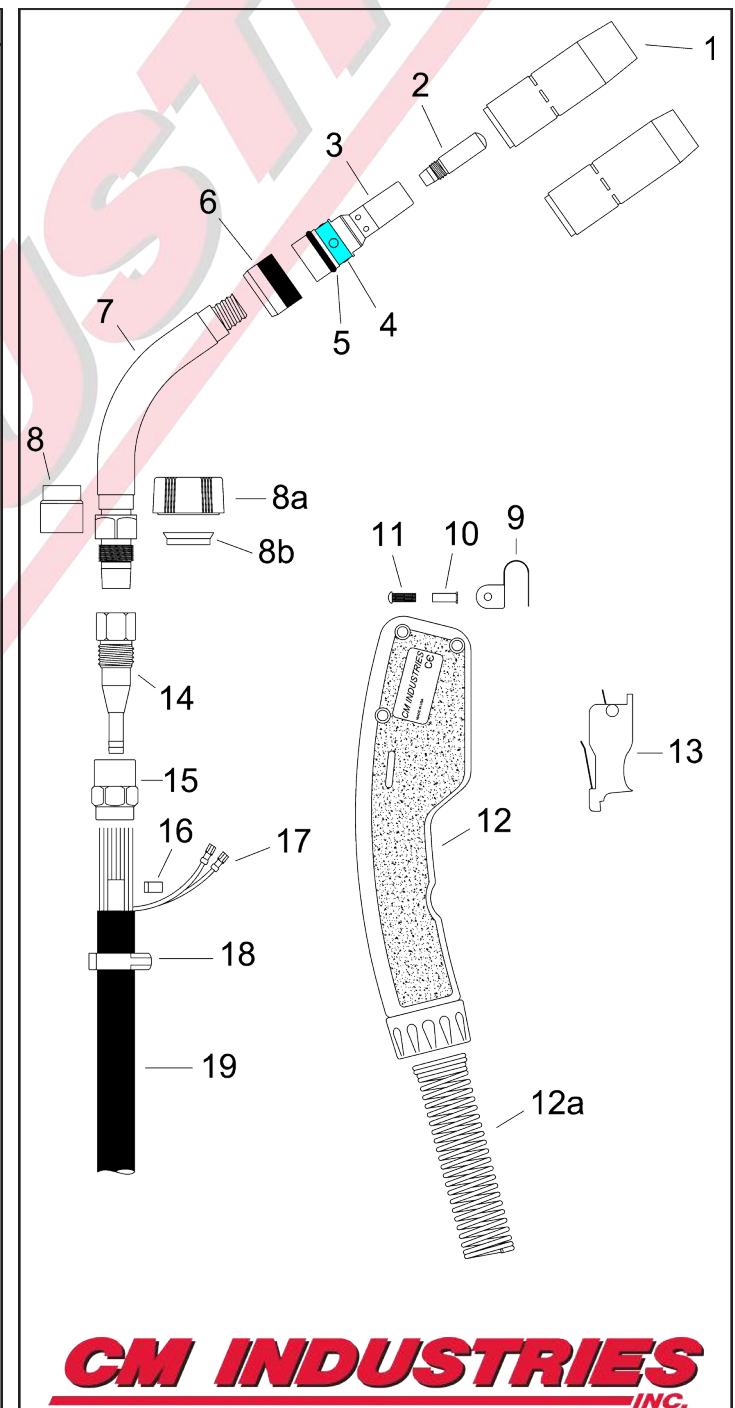

CM INDUSTRIES
INC.

#	Part Number	Description
16.	B4991	Clamp, Conduit
17.	B2660001	Trigger Terminal
18.	B4823	Clamp, Jacket
19.	B1060127	500A Cable Assembly, 10'
	B1060128	500A Cable Assembly, 12'
	B1060129	500A Cable Assembly, 15'
	B1060130	500A Cable Assembly, 20'
	B1060131	500A Cable Assembly, 25'
20.	B2520041	Strain Relief Spring
21.	B2520066	Strain Relief Kit
22.	B2280056	Screw
23.	BGN2021	Electrical Plug, Miller
24.	B4719	Electrical Plug, Lincoln
25.	B1010027R	Adaptor Block
26.	R214-1	Power Pin w/ O-Rings, Miller
27.	R214-116	Power Pin Tip, Miller .035" - 1/16"
28.	R414-11-2	O-Ring, Miller
29.	R214	Power Pin w/ O-Rings, Tweco 4
30.	R414-1	O-Ring, Tweco 4
31.	C44C	Set Screw
32.	B214-2	Power Pin, Lincoln "LN"
33.	B4816	Euro Connector Nut
34.	B5060CM	Euro Connector Plug
35.	B4421	O-Ring, Euro
36.	B2520041	Strain Relief Spring
37.	B1880074	Rigid Strain Relief Kit
38.	B4925	Locking Sleeve
39.	B4901	Quick Connect Body
40.	B4924	Lead Wire
41.	B4919	Gas Pin Assembly
42.	B4916	Wave Spring
43.	B4912	Snap Ring, Small
44.	B4911	Snap Ring, Large
45.	B2200140	Power Pin, Bernard EZ
	B1880259B	Bernard Quick Disconnect Kit (38-45)
46.	L1A-15	Liner Assembly, 15', .023"-.030"
	L2A-15	Liner Assembly, 15', .030"-.035"
	L3A-15	Liner Assembly, 15', .035"-.045"
	L4A-15	Liner Assembly, 15', .045"- 1/16"
	L6A-15	Liner Assembly, 15', 5/64"
	L7A-15	Liner Assembly, 15', 3/32"
	L8A-15	Liner Assembly, 15', 7/64"

Liners are also available in 25' lengths

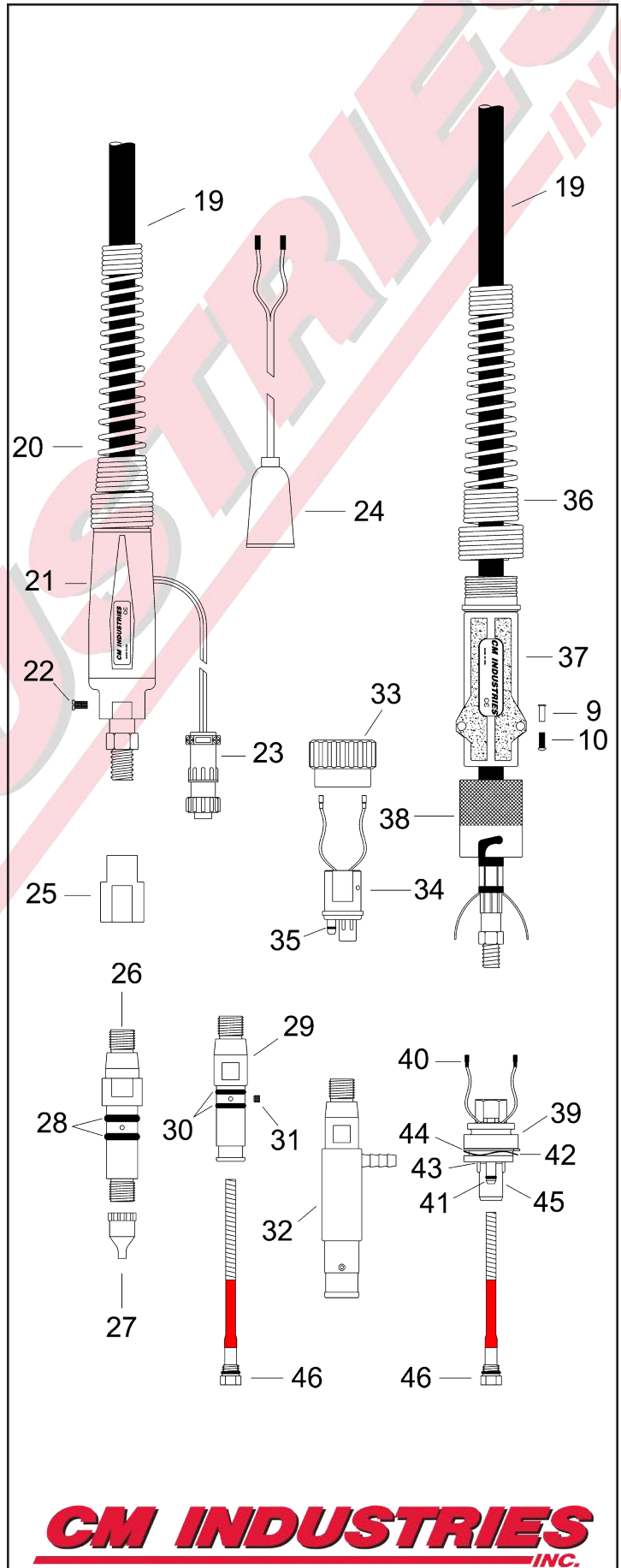

WARNING!

Please Read All Safety Instructions



WARNING

- Read and follow the manufacturer's instructions, employer's safety practices, and Material Safety Data Sheets (MSDSs).
- Only qualified personnel should install, use, or service this material and/or equipment.



ELECTRIC SHOCK can kill.

- Always wear dry installing gloves.
- Do not touch live electrical parts.
- Always disconnect power source before hooking up or changing electrodes, nozzles and other parts.



WELDING SPARKS can cause fire or explosion

- Do not weld near flammable material.
- Do not weld on closed containers.
- Remove combustibles from the work area and/or provide a fire watch.
- Avoid oily or greasy clothing as a spark may ignite them.



LOUD NOISE can damage hearing.

- Always wear protective hearing devices to ensure protection when noise levels exceed OSHA standards.



ARC RAYS can injure eyes and burn skin.

- Always wear correct eye, ear, and body protection.
- Always wear a welding helmet with the proper grade filter lens. Protect yourself and others from spatter arc rays by using protective screens, barriers and welding curtains.
- Always wear protective gloves and clothing to cover exposed skin. This will aid in the prevention of arc and spatter burns.



FUMES AND GASES can be hazardous to your health.

- Keep your head out of the fumes.
- Use enough ventilation or exhaust at the arc to keep fumes and gases from your breathing zone, and general area.
- Fumes from cutting and welding can deplete air quality, causing injury or death. Always wear an air supplied respirator in confined areas, or if breathing air is not safe.

Read America Nation Standard Z49.1, "Safety in Welding, Cutting, and Allied Processes," available from America Welding Society, 550 N.W. LeJeune Rd., Miami, FL 33126;

OSHA Safety and health standards, available from U.S. Government Printing Office, Washington DC 20402

CM INDUSTRIES

INC.

505 OAKWOOD ROAD LAKE ZURICH, IL 60047

PH: 847-550-0033 FX: 847-550-0444

www.cmindustries.com