

# BND 400TL

# AIR-COOLED MIG GUN w/ CMI "Taper-LOCK" Consumables

Replacement Suitable for Bernard®

RATING	GUN ORDERING PART NUMBER w/ CMI "Taper-LOCK" Consumables	POWER PIN Direct Connect
<b>400 Amp CO2 @ 100% Duty Cycle</b>  <b>300 Amp Mixed Gas @ 100% Duty Cycle</b>  <b>Wire Capacity: 0.030" (0.8mm) - 3/32" (2.4mm)</b>	BQ40xxAE4EBC BQ40xxAE4EEC BQ40xxAE4EHC BQ40xxAE4ELC BQ40xxAE4ESC BQ40xxAE4ERC BQ40xxAE4EMC BQ40xxAE4ETC	Bernard® Euro Hobart® Lincoln® "LN" Lincoln® "LF" Lincoln® Power MIG™ Miller® Tweco® #4
xx = Standard lengths of 10, 12, 15, 20, and 25 ft. Custom lengths also available.		

#	Part Number	Description
1.	152-10-50C 152-10-62C 152-12-38C 152-30-50C 152-30-62C 152-30-75C	Nozzle, Copper 1/2", 1/8" Tip Recess Nozzle, Copper 5/8", 1/8" Tip Recess Nozzle Tapered, Copper 3/8", Flush Nozzle H.D., Copper 1/2", 1/8" Tip Recess Nozzle H.D., Copper 5/8", 1/8" Tip Recess Nozzle H.D., Copper 3/4", 1/8" Tip Recess
<b>CMI "Taper-LOCK" Contact Tips</b>		
2.	155-1-030 155-1-035 155-1-040 155-1-045 155-1-364 155-1-052 155-1-062 155-1-564 155-1-332	H.D. Contact Tip, .030" (0.8mm) H.D. Contact Tip, .035" (0.9mm) H.D. Contact Tip, .040" (1.0mm) H.D. Contact Tip, .045" (1.2mm) H.D. Contact Tip, 3/64" (1.2mm) H.D. Contact Tip, .052" (1.4mm) H.D. Contact Tip, .062" (1.6mm) H.D. Contact Tip, 5/64" (2.0mm) H.D. Contact Tip, 3/32" (2.4mm)
3.	155-2-030 155-2-035 155-2-040 155-2-045 155-2-364 155-2-052 155-2-062	H.D. Tapered Contact Tip, .030" (0.8mm) H.D. Tapered Contact Tip, .035" (0.9mm) H.D. Tapered Contact Tip, .040" (1.0mm) H.D. Tapered Contact Tip, .045" (1.2mm) H.D. Tapered Contact Tip, 3/64" (1.2mm) H.D. Tapered Contact Tip, .052" (1.4mm) H.D. Tapered Contact Tip, .062" (1.6mm)
4.	154-R505	Diffuser H.D., for Taper-LOCK™ Tip
5.	154-R506	Diffuser, for Taper-LOCK™ Tip
5a.	154-1	Replacement Retaining Ring
5b.	154-2	Replacement O-Ring
6.	KR50-2	Neck Insulator
7.	BQT3-30 BQT3-45 BQT3-60 BQT3-80	Body Tube, Medium 30° Body Tube, Medium 45° Body Tube, Medium 60° Body Tube, Medium 80°
8.	B4780	Insulator Hex Nut
8a.	B1840057	Plastic Lock Nut
8b.	B1840031	Silicone Rubber Seal
9.	B4238	Hang Up Hook
10.	B4207	Post Fastener
11.	B4209 B1880004	Handle Screw Screw/Post Kit
12.	B1880198	Handle Kit w/ Screws
12a.	B2520042	Handle Spring
13.	B5662	Trigger Assembly
14.	B4313B	End Fitting
15.	B1540003	Cone Nut

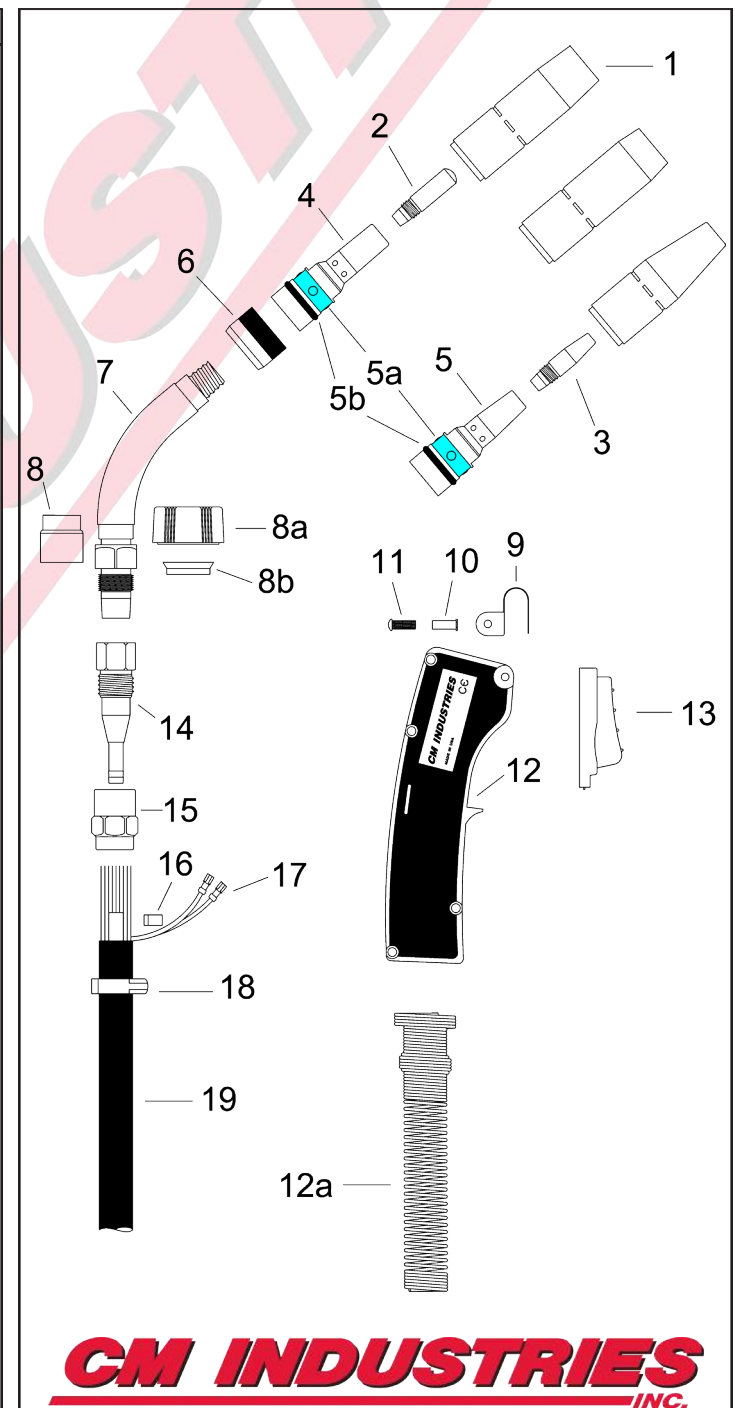

**CM INDUSTRIES**  
INC.

#	Part Number	Description
16.	B4992	Clamp, Conduit
17.	B2660001	Trigger Terminal
18.	B4823	Clamp, Jacket
19.	B1060115	400A Cable Assembly, 10'
	B1060116	400A Cable Assembly, 12'
	B1060117	400A Cable Assembly, 15'
	B1060118	400A Cable Assembly, 20'
	B1060119	400A Cable Assembly, 25'
20.	B2520041-S	Strain Relief Spring
21.	B2520066	Strain Relief Kit
22.	B2280056	Screw
23.	BGN2021	Electrical Plug, Miller
24.	B4719	Electrical Plug, Lincoln
25.	B1010027R	Adaptor Block
26.	R214-1	Power Pin w/ O-Rings, Miller
27.	R214-116	Power Pin Tip, Miller .035" - 1/16"
28.	R414-11-2	O-Ring, Miller
29.	R214	Power Pin w/ O-Rings, Tweco 4
30.	R414-1	O-Ring, Tweco 4
31.	C44C	Set Screw
32.	B214-2	Power Pin, Lincoln "LN"
33.	B4816	Euro Connector Nut
34.	B5060CM	Euro Connector Plug
35.	B4421	O-Ring, Euro
36.	B2520041-S	Strain Relief Spring
37.	B1880074	Rigid Strain Relief Kit
38.	B4925	Locking Sleeve
39.	B4901	Quick Connect Body
40.	B4924	Lead Wire
41.	B4919	Gas Pin Assembly
42.	B4916	Wave Spring
43.	B4912	Snap Ring, Small
44.	B4911	Snap Ring, Large
45.	B2200140	Power Pin, Bernard EZ
46.	B1880259B	Bernard Quick Disconnect Kit (38-45)
46.	L1A-15	Liner Assembly, 15', .023"-.030"
	L2A-15	Liner Assembly, 15', .030"-.035"
	L3A-15	Liner Assembly, 15', .035"-.045"
	L4A-15	Liner Assembly, 15', .045"- 1/16"
	L6A-15	Liner Assembly, 15', 5/64"
	L7A-15	Liner Assembly, 15', 3/32"

Liners are also available in 25' lengths

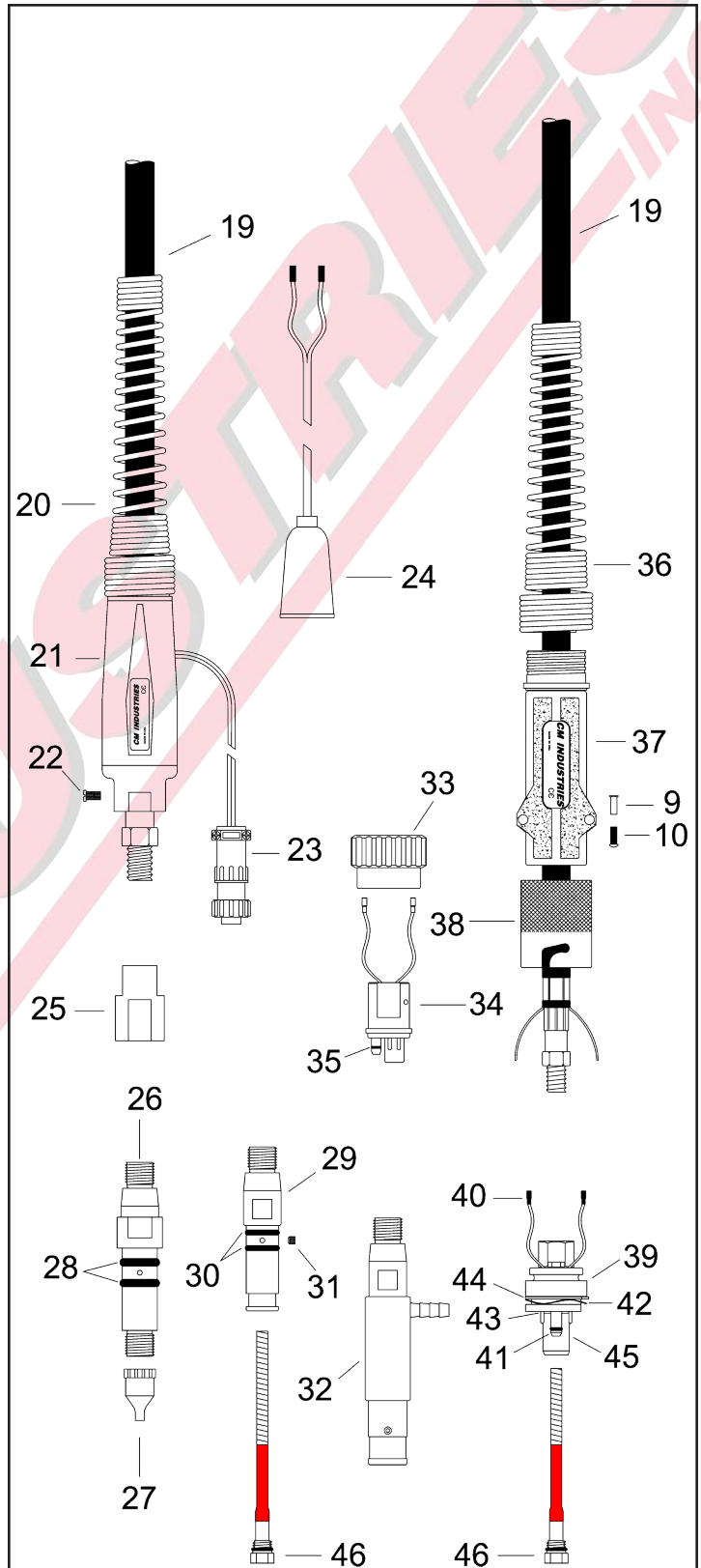

# WARNING!

## Please Read All Safety Instructions



# WARNING

- Read and follow the manufacturer's instructions, employer's safety practices, and Material Safety Data Sheets (MSDSs).
- Only qualified personnel should install, use, or service this material and/or equipment.



### **ELECTRIC SHOCK can kill.**

- Always wear dry installing gloves.
- Do not touch live electrical parts.
- Always disconnect power source before hooking up or changing electrodes, nozzles and other parts.



### **WELDING SPARKS can cause fire or explosion**

- Do not weld near flammable material.
- Do not weld on closed containers.
- Remove combustibles from the work area and/or provide a fire watch.
- Avoid oily or greasy clothing as a spark may ignite them.



### **LOUD NOISE can damage hearing.**

- Always wear protective hearing devices to ensure protection when noise levels exceed OSHA standards.



### **ARC RAYS can injure eyes and burn skin.**

- Always wear correct eye, ear, and body protection.
- Always wear a welding helmet with the proper grade filter lens. Protect yourself and others from spatter arc rays by using protective screens, barriers and welding curtains.
- Always wear protective gloves and clothing to cover exposed skin. This will aid in the prevention of arc and spatter burns.



### **FUMES AND GASES can be hazardous to your health.**

- Keep your head out of the fumes.
- Use enough ventilation or exhaust at the arc to keep fumes and gases from your breathing zone, and general area.
- Fumes from cutting and welding can deplete air quality, causing injury or death. Always wear an air supplied respirator in confined areas, or if breathing air is not safe.

Read America Nation Standard Z49.1, "Safety in Welding, Cutting, and Allied Processes," available from America Welding Society, 550 N.W. LeJeune Rd., Miami, FL 33126;

OSHA Safety and health standards, available from U.S. Government Printing Office, Washington DC 20402

## **CM INDUSTRIES**

**INC.**

505 OAKWOOD ROAD LAKE ZURICH, IL 60047

PH: 847-550-0033 FX: 847-550-0444

[www.cmindustries.com](http://www.cmindustries.com)